

# 4700R

SILENT MAGNETIC RESISTANCE

## Owner's Manual



### ⚠ WARNING ⚠

Exercise can present a health risk. Consult a physician before beginning any exercise program with this equipment. If you feel faint or dizzy, immediately discontinue use of this equipment. Serious bodily injury can occur if this equipment is not assembled and used correctly. Serious bodily injury can also occur if all instructions are not followed. Keep others and pets away from equipment when in use. Always make sure all bolts and nuts are tightened prior to each use. Follow all safety instructions in this manual.

When calling for parts or service, please specify the following number.

**15-4700**

**STAMINA PRODUCTS**

MADE IN CHINA

Product May Vary Slightly  
From Pictured.

### CAUTION:

Weight on this product should not exceed 250 lbs.

This Product is Produced Exclusively by



2040 N. Alliance, Springfield, MO 65803

Customer Service Number

1 (800) 375-7520

[www.staminaproducts.com](http://www.staminaproducts.com)

---

## TABLE OF CONTENTS

	Page		Page
Safety Instructions	2	Maintenance	12
Before You Begin	4	Conditioning Guidelines	13
Hardware Identification Chart	5	Warm-up and Cool-Down	14
Assembly Instructions	6	Warranty	15
Using The Electronic Meter	9	Product Parts Drawing	16
Set Up Instructions	10	Parts List	17
Operational Instructions	11	Fax/Mail Ordering Form	19
Storage	12		

---

## SAFETY INSTRUCTIONS

**WARNING:** To reduce the risk of serious injury, read the following Safety Instructions before using the **4700R Recumbent Bike**.

1. Read all warnings posted on the **4700R Recumbent Bike**.
2. The **4700R Recumbent Bike** should only be used after a thorough review of the Owner's Manual.
3. Keep children away from the **4700R Recumbent Bike**. Do not allow children to use or play on the **4700R Recumbent Bike**. Keep children and pets away from the **4700R Recumbent Bike** when it is in use.
4. The **4700R Recumbent Bike** is a Class A Non-free-wheeling exercise bicycle with a directly driven flywheel.
5. Spinning pedals can cause injury.
6. The **4700R Recumbent Bike** does not free wheel.
7. Pedal speed should be reduced in a controlled manner.
8. Make sure that the **4700R Recumbent Bike** is properly assembled and tightened before use.
9. Set up and operate the **4700R Recumbent Bike** on a solid level surface. Do not position the **4700R Recumbent Bike** on loose rugs or uneven surfaces.
10. Adjust the LEVELING CAPS on the REAR STABILIZER so that the **4700R Recumbent Bike** sets on the floor without rocking.
11. Inspect the **4700R Recumbent Bike** worn or loose components prior to use. Tighten/replace any any loose or worn components prior to using.
12. The ADJUSTMENT KNOB(35) should be securely tightened prior to use.
13. Each user should adjust the seat per instructions on page 11.
14. Do not attempt to adjust the seat while you are on the **4700R Recumbent Bike**.
15. Consult a physician prior to commencing an exercise program. If, at any time during exercise, you feel faint, dizzy, or experience pain, stop and consult your physician.
16. Follow your physician's recommendations in developing your own personal fitness program.
17. Always choose the workout which best fits your physical strength and flexibility level. Know your limits and train within them. Always use common sense when exercising.
18. Do not wear loose or dangling clothing while using the **4700R Recumbent Bike**.
19. Never exercise in bare feet or socks; always wear correct footwear, such as running, walking, or crosstraining shoes. Be sure that they fit well, provide foot support and feature non-skid rubber soles.
20. Care should be taken in mounting or dismounting the **4700R Recumbent Bike**.
21. The **4700R Recumbent Bike** should not be used by persons weighing over 250 pounds.
22. The **4700R Recumbent Bike** should be used by only one person at a time.
23. The **4700R Recumbent Bike** is for consumer use only. It is not for use in public or semipublic facilities.

**WARNING:** Before starting any exercise or conditioning program you should consult with your personal physician to see if you require a complete physical exam. This is especially important if you are over the age of 35, have never exercised before, are pregnant, or suffer from any illness. **READ AND FOLLOW THE SAFETY PRECAUTIONS. FAILURE TO FOLLOW THESE INSTRUCTIONS CAN RESULT IN SERIOUS BODILY INJURY.**

CALL US FIRST



**CUSTOMER SERVICE NUMBER**  
**1 (800) 375-7520**

---

**THANK YOU FOR PURCHASING THE**  
**4700R Recumbent Bike**

To help you get started, we have pre-assembled most of your 4700R Recumbent Bike at the factory with the exception of those few parts left unassembled for shipping purposes. Simply follow the few assembly instructions set forth in this manual. Within a few minutes you will be getting your body into shape and on your way to achieving a happier and healthier lifestyle.

Should you have any questions,  
please call our Customer Service Department toll-free number,  
**1 (800) 375-7520**  
Monday - Friday, 8:00 A.M. - 5:00 P.M., Central Time.

## BEFORE YOU BEGIN

Thank you for choosing the **4700R Recumbent Bike**. We take great pride in producing this quality product and hope it will provide many hours of quality exercise to make you feel better, look better and enjoy life to its fullest.

Yes, it's a proven fact that a regular exercise program can improve your physical and mental health. Too often, our busy lifestyles limit our time and opportunity to exercise. The **4700R Recumbent Bike** provides a convenient and simple method to begin your assault on getting your body in shape and achieving a happier and healthier lifestyle.

Before reading further, please review the drawing below and familiarize yourself with the parts that are labeled.

Read this manual carefully before using the **4700R Recumbent Bike**.

Although Stamina tries to manufacture its products with the finest materials and uses the highest standards of manufacturing, occasionally a part that does not fit, is the incorrect size, or is otherwise inappropriate is found. Even with the highest inspection and quality controls in place these things will happen occasionally. Please do not return the product. For your convenience, Stamina has a Customer Service Department with a toll-free number. If a part is missing, does not fit, is the incorrect size, or is otherwise inappropriate, please call 1 (800) 375-7520 (in the U.S.) between 8:00 A.M. and 5:00 P.M. Central Time, Monday through Friday. Our operators will be able to assist you with your problem and the parts will be mailed directly to your house.

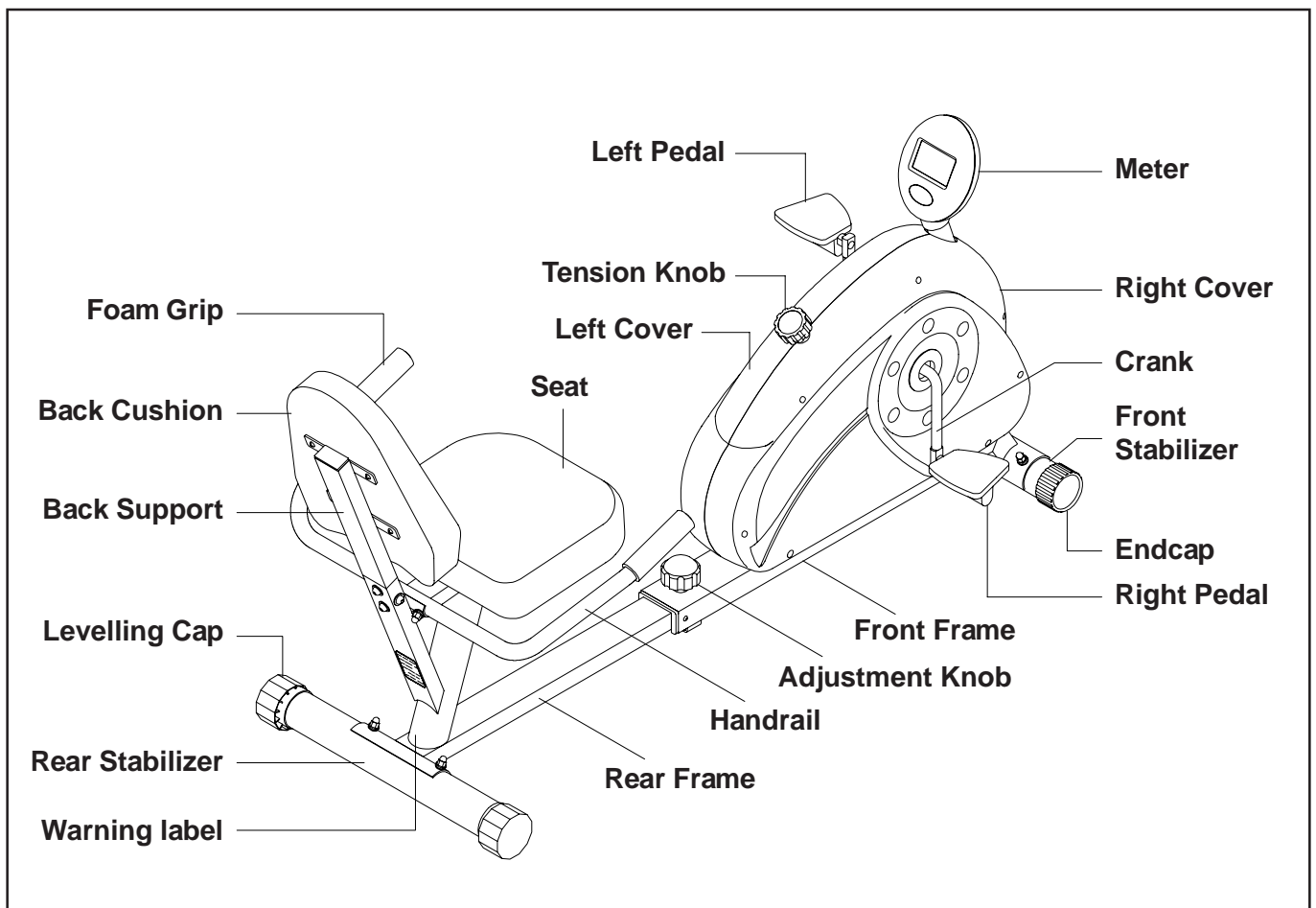

THE FOLLOWING TOOLS ARE INCLUDED FOR ASSEMBLY :



Wrench

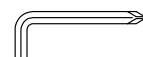

Allen Wrench (6mm)

# HARDWARE IDENTIFICATION CHART

This chart is provided to help identify the hardware used in the assembly process. After unpacking the unit, open the hardware bag and make sure that you have the following items:

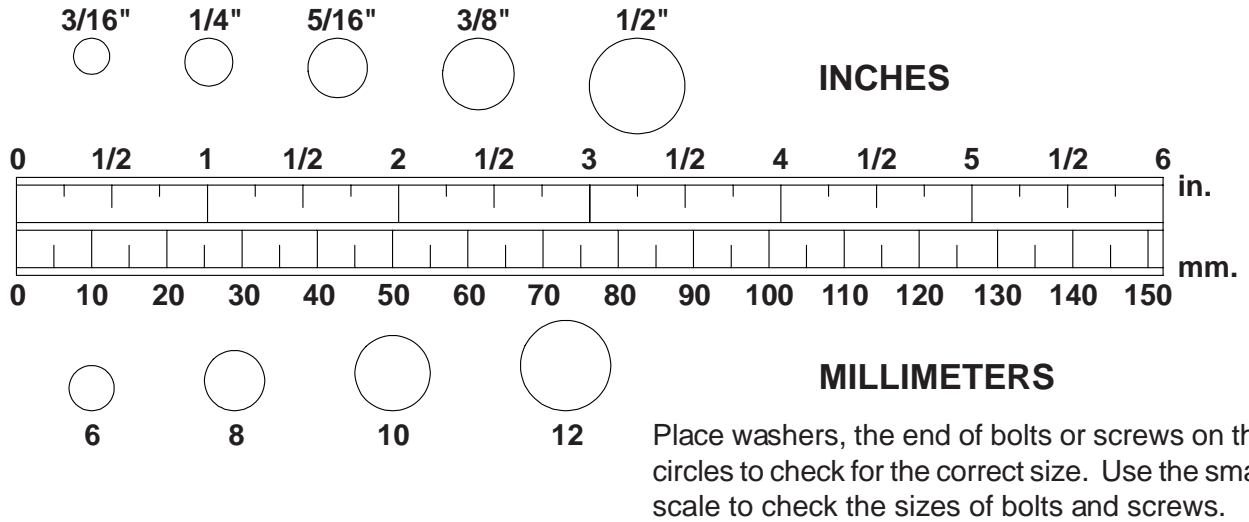

Length	Part No. and Description	Qty
	45 Carriage Bolt (M8 x 1.25 x 40mm)	2
	46 Carriage Bolt (M8 x 1.25 x 65mm)	4
	47 Bolt, Round Head (M6 x 1 x 20mm)	8
	48 Bolt, Button Head (M8 x 1.25 x 15mm)	4
	55 Screw, Round Head (M4 x 15mm)	1
	59 Acorn Nut (M8 x 1.25)	6
	62 Arc Washer (M8)	6
	63 Washer (M8)	4
	65 Lock Washer (M8)	6

**NOTE:** Some of the hardware items listed may be attached to other parts.

## ASSEMBLY INSTRUCTIONS

Place all parts from the box in a cleared area and position them on the floor in front of you. Remove all packing materials from your area and place them back into the box. Do not dispose of the packing materials until assembly is completed. Read each step carefully before beginning. If you are missing a part please call our toll-free number for assistance **1 (800) 375-7520** or e-mail us at:

**parts@staminaproducts.com**

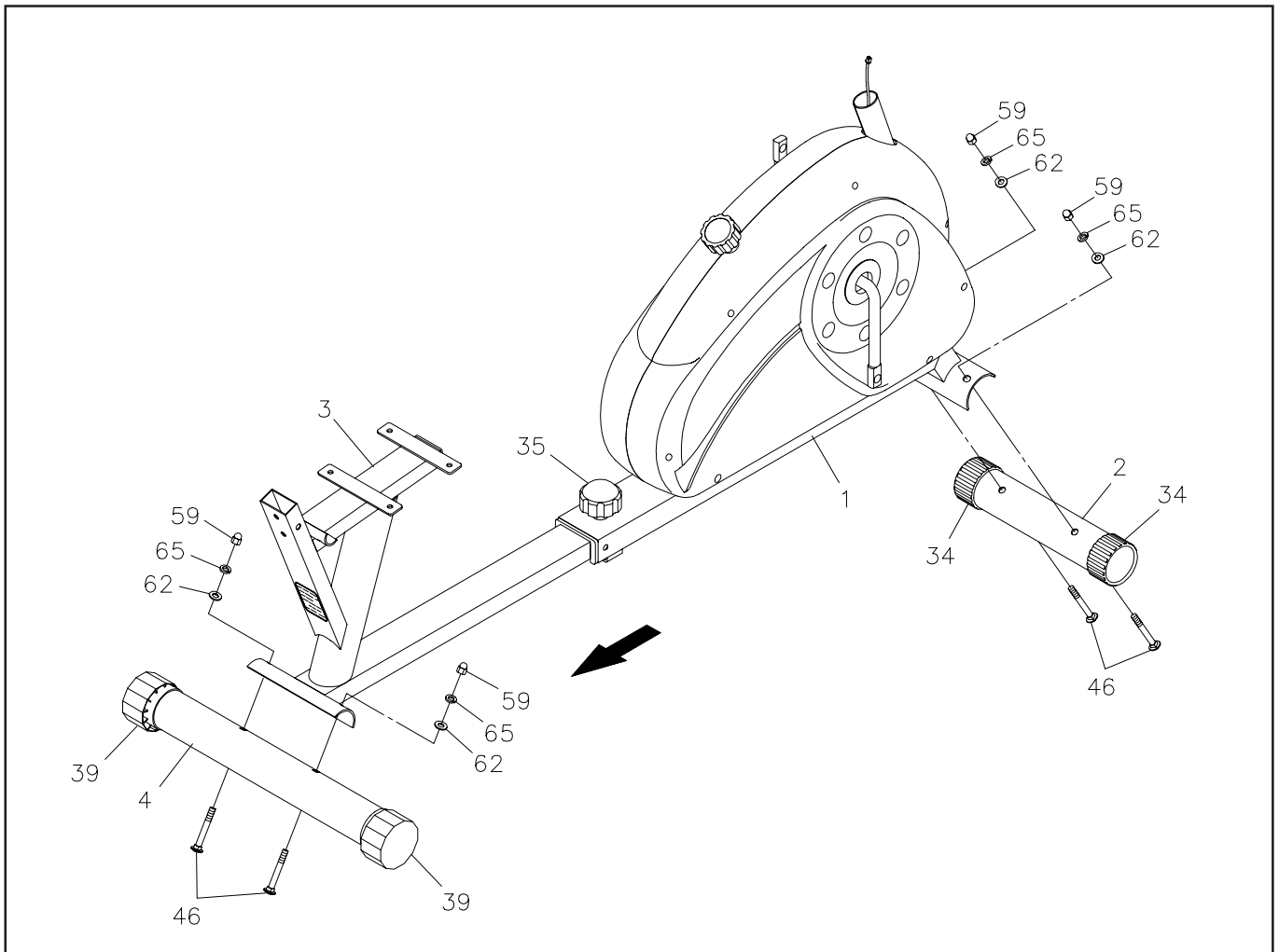

### STEP 1

Attach the **FRONT STABILIZER(2)**, the short one with the round **ENDCAPS(34)**, onto the front of the **MAIN FRAME(1)** with **CARRIAGE BOLTS(M8 x 65mm)(46)**, **ARC WASHERS(M8)(62)**, **LOCK WASHERS(M8)(65)**, and **ACORN NUTS(M8)(59)**.

### STEP 2

Loosen the **ADJUSTMENT KNOB(35)** on the **FRONT FRAME(1)**. Slide the **REAR FRAME(3)** backward and secure with the **ADJUSTMENT KNOB(35)**. Attach the **REAR STABILIZER(4)**, the one with the **LEVELING CAPS(39)**, onto the **REAR FRAME(3)** with **CARRIAGE BOLTS(M8 x 65mm)(46)**, **ARC WASHERS(M8)(62)**, **LOCK WASHERS(M8)(65)**, and **ACORN NUTS(M8)(59)**.

**NOTE:** You can adjust the **LEVELING CAPS(39)** on the **REAR STABILIZER(4)** to keep the Recumbent Bike stable.

## ASSEMBLY INSTRUCTIONS

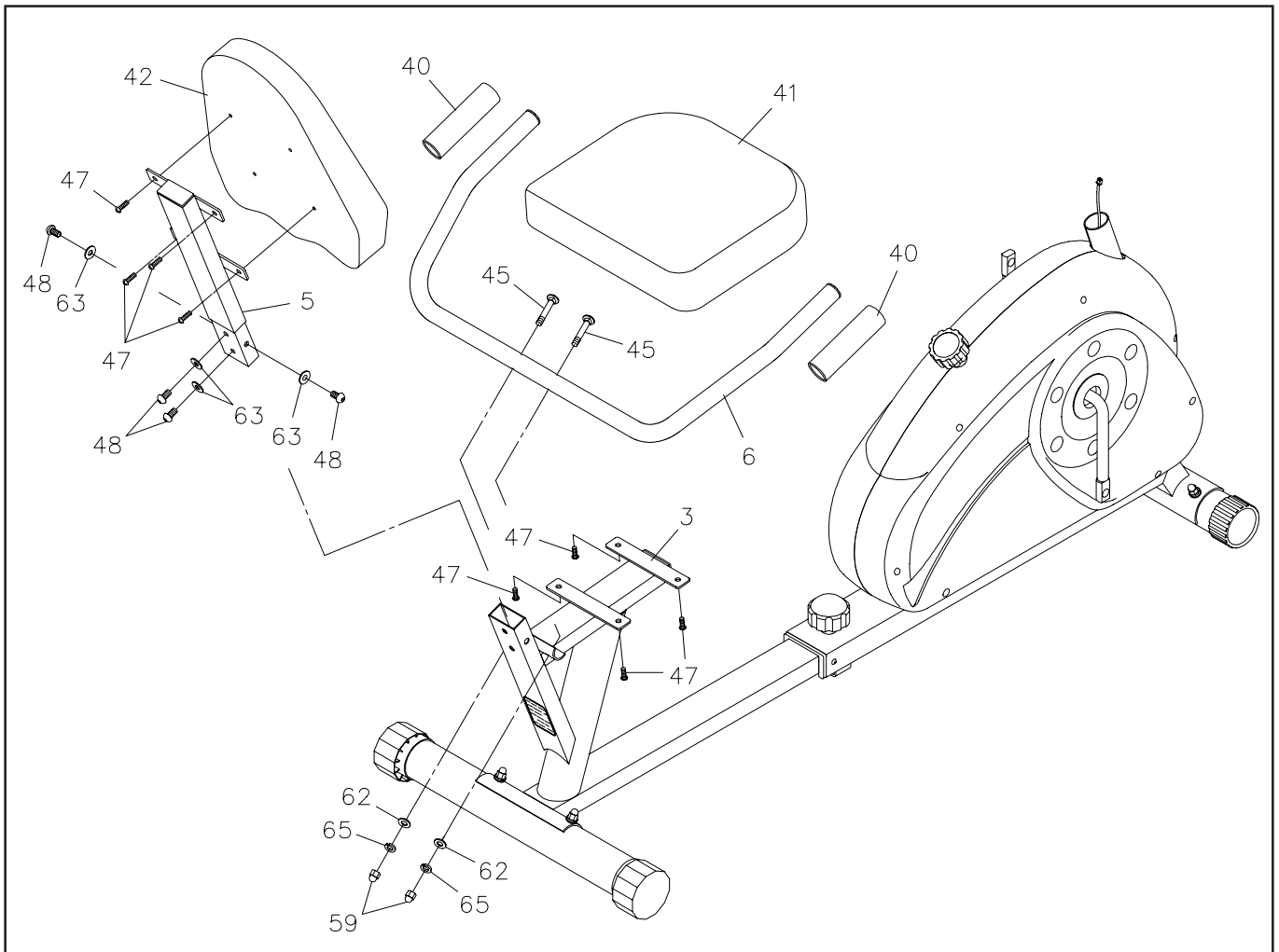

### STEP 3

Attach the **HANDRAIL(6)** onto the **REAR FRAME(3)** with **CARRIAGE BOLTS(M8 x 40mm)(45)**, **ARC WASHERS(M8)(62)**, **LOCK WASHERS(M8)(65)**, and **ACORN NUTS(M8)(59)**. Slide the **FOAM GRIPS(40)** onto both sides of **HANDRAIL(6)**.

**NOTE:** Lubricate the **HANDRAIL(6)** with soap and water to allow for easier installation.

### STEP 4

Attach the **SEAT(41)** onto the **REAR FRAME(3)** with **ROUND HEAD BOLTS(M6 x 20mm)(47)**.

### STEP 5

Attach the **BACK SUPPORT(5)** onto the **REAR FRAME(3)** with **BUTTON HEAD BOLTS(M8 x 15mm)(48)** and **WASHER(M8)(63)**. Attach the **BACK CUSHION(42)** onto the **BACK SUPPORT(5)** with **ROUND HEAD BOLTS(M6 x 20mm)(47)**.

## ASSEMBLY INSTRUCTIONS

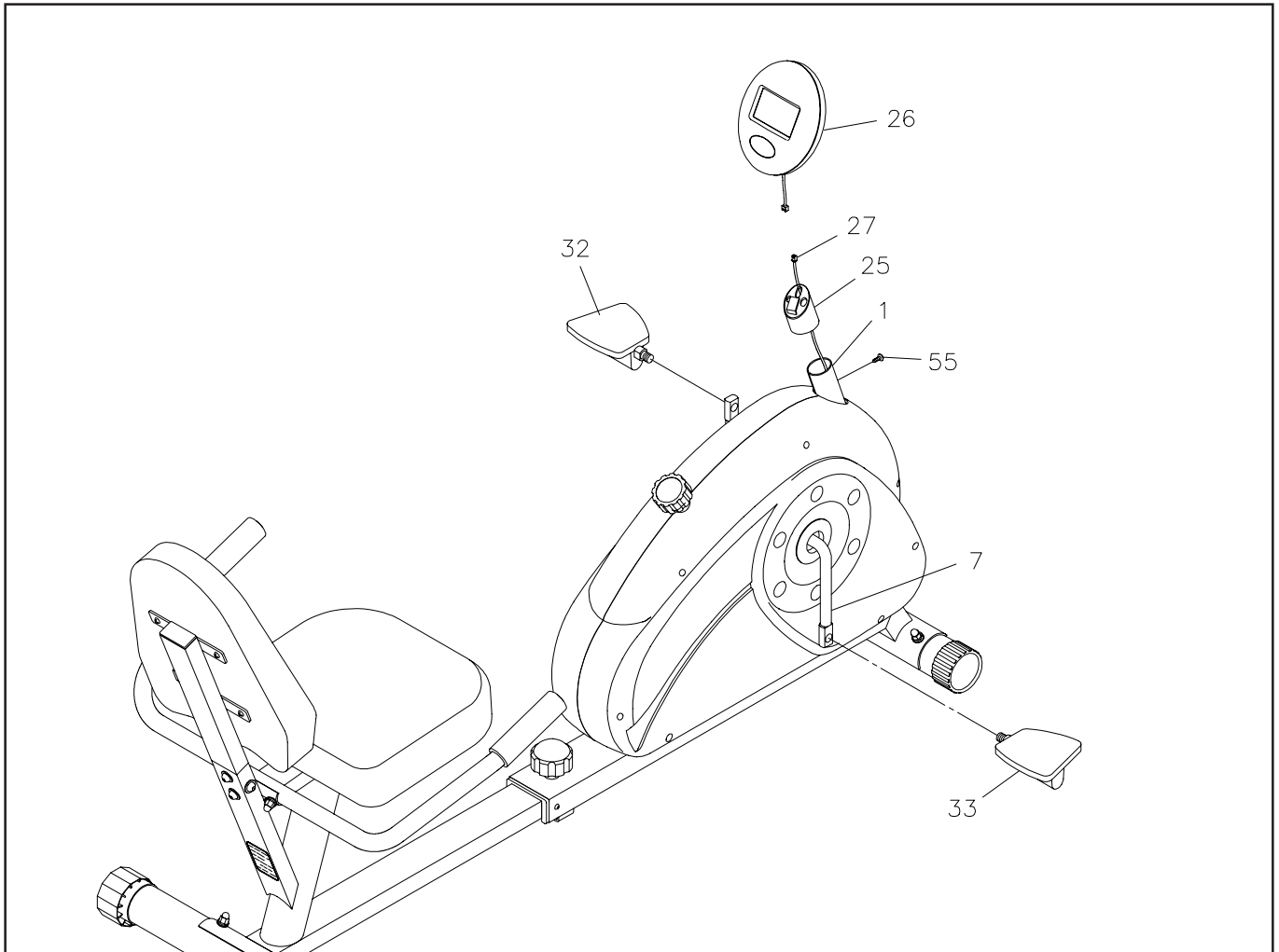

### STEP 6

**NOTE:** The **RIGHT PEDAL(33)** has **R** stamped on the end of the pedal shaft. The **RIGHT PEDAL(33)** has right hand threads and is tightened by turning clockwise. The **LEFT PEDAL(32)** has **L** stamped on the end of the pedal shaft. The **LEFT PEDAL(32)** has left hand threads and is tightened by turning counter clockwise.

Thread the **RIGHT PEDAL(33)** onto the right side of the **CRANK(7)** as shown. Tighten the pedal securely. Do the same to attach the **LEFT PEDAL(32)** onto the left side of the **CRANK(7)**.

### STEP 7

Run the **SENSOR WIRE(27)** through the **METER POST(25)**. Then slide the **METER POST(25)** onto the **FRONT FRAME(1)** and secure with **SCREW(M4 x 15mm)(55)**.

### STEP 8

Install two "AA" batteries into the **METER(26)**, two batteries included. See page 9 for detailed battery installation instructions. Plug the **SENSOR WIRE(27)** to the **METER(26)**, and push the excess wires back into the **METER POST(25)**. Slide the **METER(26)** onto the **METER POST(25)**.

**NOTE:** Be careful not to damage the wires when attaching the **METER(26)**.

## USING THE METER

**POWER ON :** Pedal movement or push the **BUTTON**.

**POWER OFF :** Automatic shut off after 2 minutes of inactivity.

### FUNCTION BUTTON:

Press to select lower display functions. Lower display functions include **SCAN**, **DISTANCE**, **TIME**, and **CALORIES**.

Press and hold for three seconds to reset all functions to zero.

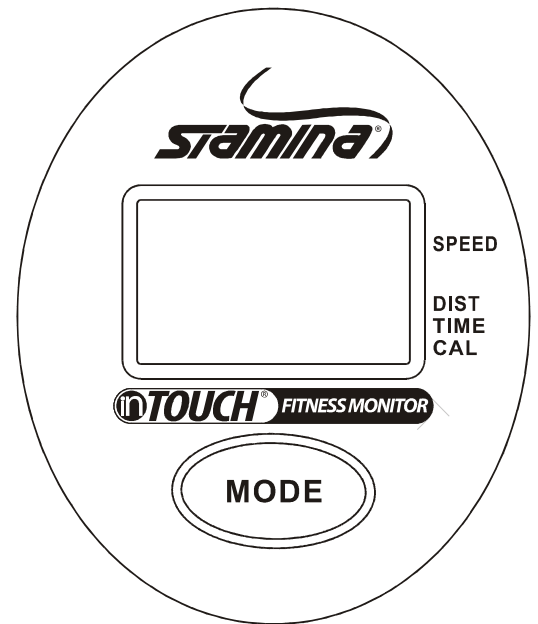

### FUNCTIONS:

**SPEED:** Displays the current speed on upper display, from zero to 999.9 Mile/Hr.

**SCAN:** Lower display automatically scans **DISTANCE**, **TIME**, and **CALORIES** in sequence with a change every four seconds. Press and release the **BUTTON** until "**SCAN**" appears on the display.

**DISTANCE:** Displays the distance, from zero to 999.9 miles.

**TIME:** Displays the time, from 1 sec. up to 99:59 minutes.

**CALORIES:** Displays the calorie consumption, from zero to 999.9 cal. The calorie readout is an estimate for an average user. It should be used only as a comparison between workouts on this unit.

**NOTE:** The meter will shut off automatically after 2 minutes of inactivity. All function values will be kept. Press the **BUTTON** and hold it down for three seconds to reset all functions to zero.

### HOW TO INSTALL AND REPLACE BATTERIES:

1. Open the Battery Door on the back of the meter.
2. The meter operates with two AA batteries, two batteries included. Refer to the illustration to install or replace the batteries.

### NOTE:

1. Do not mix a new battery with an old battery.
2. Use the same type of battery. Do not mix an alkaline battery with another type of battery.
3. Rechargeable batteries are not recommended.

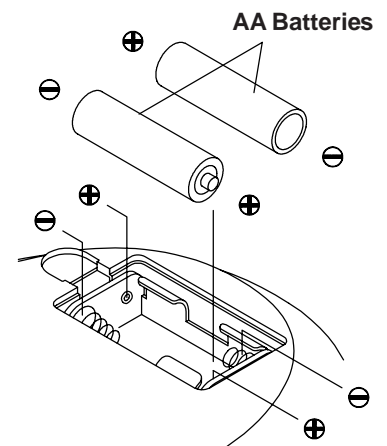

---

## SET UP INSTRUCTIONS

Place the **4700R Recumbent Bike** in the area where it will be used. The **4700R Recumbent Bike** is approximately 60 1/4" long x 26 3/4" wide x 32" tall. (These dimensions may vary up to one inch.) An area 4 feet wide x 7 feet long is required for safe operation of the **4700R Recumbent Bike**. Make sure that adequate space is available for access to and passage around the **4700R Recumbent Bike**.

**LEVELING:** Adjust the **LEVELING CAPS(39)** on the **REAR STABILIZER(4)** so that the Recumbent Bike sets on the floor without rocking. Remove and reposition the **LEVELING CAPS(39)** on the **REAR STABILIZER(4)** to level the **4700R Recumbent Bike**.

**MOVING:** The **4700R Recumbent Bike** must be lifted for movement. Two people may be required. Grasp on the **FRONT STABILIZER(2)** and **REAR STABILIZER(4)** to move the **4700R Recumbent Bike**.

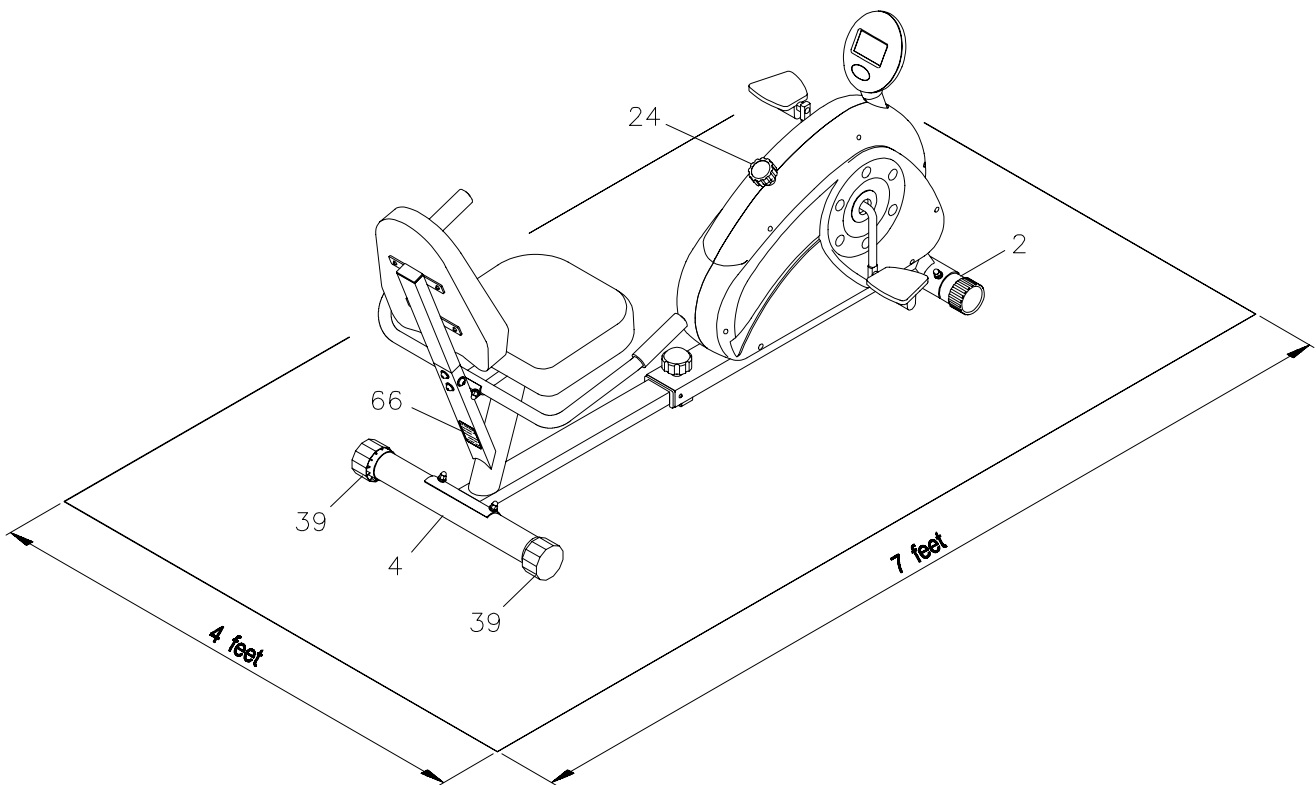

### FUNCTION INSPECTION:

Visually inspect the **4700R Recumbent Bike** to verify that assembly is as shown in the above illustration. Check the function of the **4700R Recumbent Bike**. Turn the crank slowly through one complete revolution to verify that the drive train functions properly. Adjust the **TENSION KNOB(24)** and verify that it functions properly.

**CAUTION:** Locate and read the **WARNING LABEL(66)** on the **4700R Recumbent Bike**. Make sure that all users read the **WARNING LABEL(66)**.

---

## OPERATIONAL INSTRUCTIONS

### SEAT ADJUSTMENT

Proper seat adjustment is important.

1. Loosen the **ADJUSTMENT KNOB(35)** and slide the **REAR FRAME(3)** to adjust the seat. Tighten the **ADJUSTMENT KNOB(35)** after adjusting the seat to a new position.
2. Sit on the seat and place your feet on the pedals. You should be able to move through a complete pedal stroke without locking your knees or shifting your hips on the seat. The seat is too close to the pedals if you have more than a slight bend in your knees at the bottom of the pedal stroke. The seat is too far from the pedals if you have to completely straighten your knees at the bottom of the pedal stroke. Refer to the illustration below.

#### CAUTION:

1. Do not attempt to adjust the seat while you are on the **4700R Recumbent Bike**.
2. Always tighten the **ADJUSTMENT KNOB(35)** after adjusting the seat to a new position.

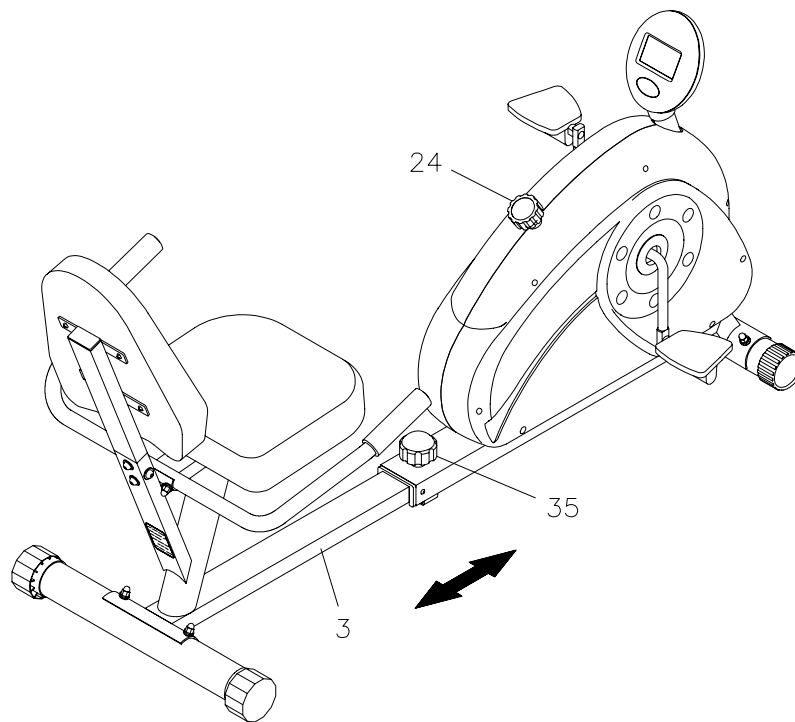

### LOAD ADJUSTMENT

To increase the load, turn the **TENSION KNOB(24)** clockwise. To decrease the load, turn the **TENSION KNOB(24)** counterclockwise.

---

## STORAGE

1. To store the **4700R Recumbent Bike** simply keep it in a clean dry place.
2. Adjust the **REAR FRAME(3)** into the **FRONT FRAME(1)** to the shortest position. The **4700R Recumbent Bike** is approximately 41" long x 26 3/4" wide x 32" tall. These dimensions will vary. Please measure your **4700R Recumbent Bike** if exact dimensions are needed.
3. Lift the **4700R Recumbent Bike** from the **FRONT STABILIZER(2)** and **REAR STABILIZER(4)** to move.
4. To avoid damage to the electronics, remove the batteries before storing the **4700R Recumbent Bike** for one year or more.

## MAINTENANCE

The safety and integrity designed into the **4700R Recumbent Bike** can only be maintained when the **4700R Recumbent Bike** is regularly examined for damage and wear. Special attention should be given to the following:

1. Adjust the **TENSION KNOB(24)** and verify that the Magnetic System provides tension. The Magnetic System should provide many years of use.
2. Use a wrench to verify that the pedals are tightened securely. If tightening is required, remember that the left pedal has left hand threads and is tightened by turning counterclockwise.
3. Verify that the Warning Label is in place and easy to read. Call Stamina Products immediately (1-800-375-7520) for a replacement Warning Label if the Warning Label is missing or damaged.
4. It is the sole responsibility of the user/owner to ensure that regular maintenance is performed.
5. Worn or damaged components shall be replaced immediately or the **4700R Recumbent Bike** removed from service until repair is made.
6. Only Stamina Products supplied components shall be used to maintain/repair the **4700R Recumbent Bike**.
7. Keep your **4700R Recumbent Bike** clean by wiping with an absorbent cloth after use.

## CONDITIONING GUIDELINES

How you begin your exercise program depends on your physical condition. If you have been inactive for several years, or are severely overweight, you must start slowly and increase your time on the **4700R Recumbent Bike** gradually: a few minutes per workout.

Initially, you may be able to exercise only for a few minutes in your target zone, however, your aerobic fitness will improve over the next six to eight weeks. Don't be discouraged if it takes longer. It's important to work at your own pace. Ultimately, you'll be able to exercise continuously for 30 minutes. The better your aerobic fitness, the harder you will have to work to stay in your target zone. Please remember these essentials:

- Have your doctor review your training and diet programs to advise you of a workout routine you should adopt.
- Begin your training program slowly with realistic goals that have been set by you and your doctor.
- Monitor your pulse frequently. Establish your target heart rate base on your age and condition.
- Set up your **4700R Recumbent Bike** on a flat, even surface at least 3 feet from walls and furniture.

## EXERCISE INTENSITY

To maximize the benefits of exercising, it is important to exercise with the proper intensity. The proper intensity level can be found by using your heart rate as a guide. For effective aerobic exercise, your heart rate should be maintained at a level between 70% and 85% of your maximum heart rate as you exercise. This is known as your target zone. You can find your target zone in the table below. Target zones are listed for both unconditioned and conditioned persons according to age.

AGE	UNCONDITIONED TARGET ZONE (BEATS/MIN.)	CONDITIONED TARGET ZONE (BEATS/MIN.)
20	138~167	133~162
25	136~166	132~160
30	135~164	130~158
35	134~162	129~156
40	132~161	127~155
45	131~159	125~153
50	129~156	124~150
55	127~155	122~149
60	126~153	121~147
65	125~151	119~145
70	123~150	118~144
75	122~147	117~142
80	120~146	115~140
85	118~144	114~139

During the first few months of your exercise program, keep your heart rate near the low end of your target zone as you exercise. After a few months, your heart rate can be increased gradually until it is near the middle of your target zone as you exercise.

To measure your heart rate, stop exercising but continue moving your legs or walking around and place two fingers on your wrist. Take a six-second heartbeat count and multiply the results by 10 to find your heart rate. For example, if your six-second heartbeat count is 14, your heart rate is 140 beats per minute. (A six-second count is used because your heart rate will drop rapidly when you stop exercising.) Adjust the intensity of your exercise until your heart rate is at the proper level.

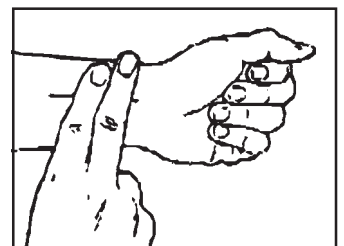

---

## WARM-UP and COOL-DOWN

**Warm-up** The purpose of warming up is to prepare your body for exercise and to minimize injuries. Warm up for two to five minutes before strength-training or aerobic exercising. Perform activities that raise your heart rate and warm the working muscles. Activities may include brisk walking, jogging, jumping jacks, jump rope, and running in place

**Stretching** Stretching while your muscles are warm after a proper warm-up and again after your strength or aerobic training session is very important. Muscles stretch more easily at these times because of their elevated temperature, which greatly reduces the risk of injury. Stretches should be held for 15 to 30 seconds. Do not bounce.

### Suggested Stretching Exercises

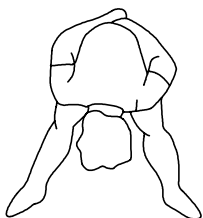

#### Lower Body Stretch

Place feet shoulder-width apart and lean forward. Keep this position for 30 seconds using the body as a natural weight to stretch the backs of the legs.

**DO NOT BOUNCE!**

When the pull on the back of the legs lessen, try a lower position gradually.



#### Floor Stretch

While sitting on the floor, open the legs as wide as possible. Stretch the upper body toward the knee on the right leg by using your arms to pull your chest to your thighs. Hold this stretch 10 to 30 seconds.

**DO NOT BOUNCE!**

Do this stretch 10 times. Repeat the stretch with the left leg.

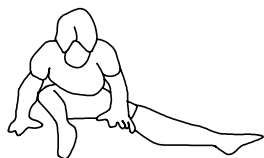

#### Bent Torso Pulls

While sitting on the floor, have legs apart one leg straight and one knee bent. Pull the chest down to touch the thigh on the leg that is bent and twist at the waist. Hold this position at least 10 seconds. Repeat 10 times on each side.

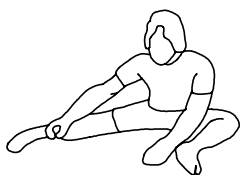

#### Bent Over Leg Stretch

Stand with feet shoulder-width apart and lean forward as illustrated. Using the arms, **gently** pull the upper body towards the right leg. Let the head hang down. **DO NOT BOUNCE!**

Hold the position a minimum of 10 seconds. Repeat pulling the upper body to the left leg. Do this stretch several times slowly.

**Remember always to check with your physician before starting any exercise program.**

**Cool-Down** The purpose of cooling down is to return the body to its normal, or near normal, resting state at the end of each exercise session. A proper cool-down slowly lowers your heart rate and allows blood to return to the heart. Your cool-down should include the stretches listed above and should be completed after each strength-training session.

WARRANTY

Stamina Products, Inc. warrants that this product will be free from defects in materials and workmanship under normal use, service and proper operation for a period of 90 days on the parts and one year on the frame from the date of the original purchase from an authorized retailer. **THIS WARRANTY SHALL NOT APPLY TO ANY PRODUCT WHICH HAS BEEN SUBJECT TO COMMERCIAL USE, ABUSE, MISUSE, ALTERATION OF ANY TYPE OR CAUSE OR TO ANY DEFECT OR DAMAGE CAUSED BY REPAIR, REPLACEMENT, SUBSTITUTION OR USE WITH PARTS OTHER THAN PARTS PROVIDED BY STAMINA PRODUCTS, INC.** Commercial use includes use of the product in athletic clubs, health clubs, spas, gymnasiums, exercise facilities, and other public or semipublic facilities whether or not the product's use is in furtherance of a profit making enterprise, and all other use which is not for personal, family, or household purposes.

To implement this limited warranty, send a written notice stating your name, date, and place of purchase and a brief description of the defect along with your receipt to **Stamina Products, Inc. P.O. Box 1071, Springfield Missouri, USA, 65801-1071** or call us at **1 (800) 375-7520**. If the defect is covered under this limited warranty, you will be requested to return the product or part to us for free repair or replacement at our option. **NO ACTION FOR BREACH OF THIS LIMITED WARRANTY MAY BE COMMENCED MORE THAN ONE (1) YEAR AFTER THE DATE THE ALLEGED BREACH WAS OR SHOULD HAVE BEEN DISCOVERED. NO ACTION FOR BREACH OF ANY IMPLIED WARRANTY MAY BE COMMENCED MORE THAN ONE (1) YEAR AFTER DELIVERY OF THE PRODUCT TO THE PURCHASER.** This limited warranty is not transferable. **IF ANY PART OF THE PRODUCT IS NOT IN COMPLIANCE WITH THIS LIMITED WARRANTY OR ANY IMPLIED WARRANTY, THE REMEDY OF REPAIR OR REPLACEMENT IS THE EXCLUSIVE REMEDY AVAILABLE TO YOU.** In the event that the purchaser makes any claim under this limited warranty or any implied warranty, the Warrantor reserves the right to require the product to be returned for inspection, at the purchaser's expense, to the Warrantor's premises in Springfield, Missouri. Return of the enclosed warranty registration card is not required for warranty coverage, but is merely a way of establishing the date and place of purchase.

Stamina Products, Inc. **SHALL NOT BE LIABLE FOR THE LOSS OF USE OF ANY PRODUCT, LOSS OF TIME, INCONVENIENCE, COMMERCIAL LOSS OR ANY OTHER INDIRECT, CONSEQUENTIAL, SPECIAL OR INCIDENTAL DAMAGES DUE TO BREACH OF THE ABOVE WARRANTY OR ANY IMPLIED WARRANTY.**

This limited warranty is the only written or express warranty given by Stamina Products, Inc. This warranty gives you specific legal rights, and you may also have other legal rights which vary from state to state. **ANY OTHER RIGHT WHICH YOU MAY HAVE, INCLUDING ANY IMPLIED WARRANTY OR MERCHANTABILITY OR FITNESS FOR A PARTICULAR PURPOSE, IS LIMITED IN DURATION TO THE DURATION OF THIS WARRANTY.**

The laws in some jurisdictions restrict the rights of manufacturers and distributors of consumer goods to disclaim or limit implied warranties and consequential and incidental damages with respect thereto. If any such law is found to be applicable, the foregoing disclaimers and limitations of and on implied warranties and consequential and incidental damages with respect thereto shall be disregarded and shall be deemed not to have been made to the extent necessary to comply with such legal restriction.

# PRODUCT PARTS DRAWING

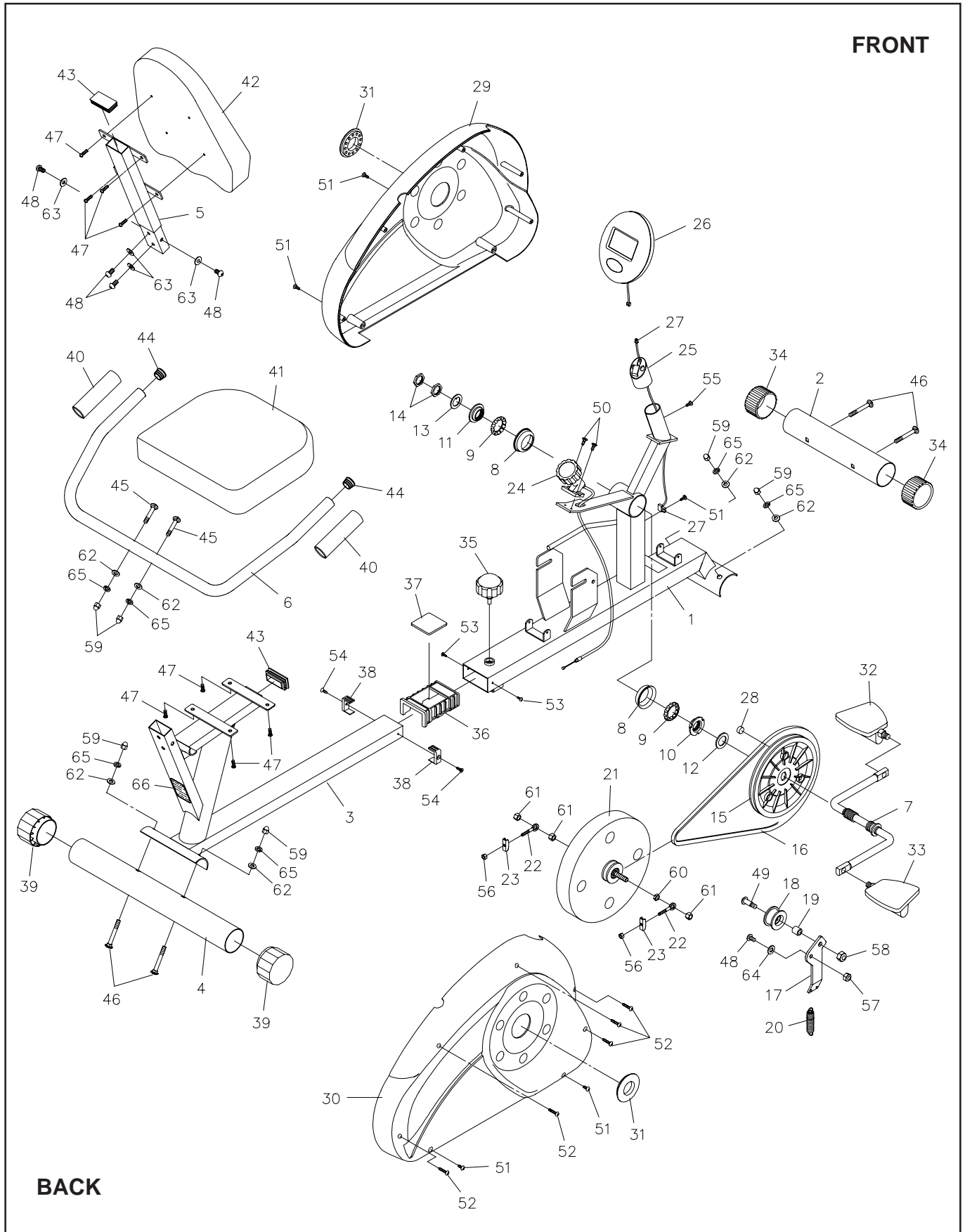

---

## PARTS LIST

DIAGRAM#	PART NAME	QTY
1	Front Frame	1
2	Front Stabilizer	1
3	Rear Frame	1
4	Rear Stabilizer	1
5	Back Support	1
6	Handrail	1
7	Crank	1
8	Bearing Housing	2
9	Ball Bearing	2
10	Inside Bearing Collar	1
11	Outside Bearing Collar	1
12	Bearing Washer	1
13	Bearing Snap Washer	1
14	Bearing Nut	2
15	Pulley	1
16	V Belt	1
17	Idler Arm	1
18	Idler Wheel	1
19	Idler Wheel Bushing	1
20	Tension Spring	1
21	Magnetic Unit	1
22	Eyebolt	2
23	Tension Bracket	2
24	Tension Knob	1
25	Meter Post	1
26	Meter	1
27	Sensor Wire	1
28	Magnet	1
29	Left Cover	1
30	Right Cover	1
31	Cover Cap	2
32	Left Pedal	1
33	Right Pedal	1
34	Endcap (50mm)	2
35	Adjustment Knob	1
36	Bushing	1
37	Press Plate	1
38	End Stopper	2
39	Levelling Cap (50mm)	2
40	Foam Grip	2
41	Seat	1
42	Back Cushion	1
43	Rectangular Plug (30mm x 60mm)	2
44	Round Plug (25mm)	2
45	Carriage Bolt (M8 x 1.25 x 40mm)	2

---

## PARTS LIST

DIAGRAM#	PART NAME	QTY
46	Carriage Bolt (M8 x 1.25 x 65mm)	4
47	Bolt, Round Head (M6 x 1 x 20mm)	8
48	Bolt, Button Head (M8 x 1.25 x 15mm)	5
49	Bolt, Button Head (M10 x 1.5 x 40mm)	1
50	Screw, Flat Head (M5 x 0.8 x 8mm)	2
51	Screw, Round Head (M5 x 15mm)	5
52	Screw, Small Round Head (M5 x 25mm)	5
53	Screw, Round Head (M4 x 8mm)	2
54	Screw, Round Head (M4 x 10mm)	2
55	Screw, Round Head (M4 x 15mm)	1
56	Nylock Nut (M6 x 1)	2
57	Thin Nylock Nut (M8 x 1.25)	1
58	Nylock Nut (M10 x 1.5)	1
59	Acorn Nut (M8 x 1.25)	6
60	Thin Nut (3/8" - 26 x 5/32" thick)	1
61	Nut (3/8" - 26 x 5/16" thick)	3
62	Arc Washer (M8)	6
63	Washer (M8)	4
64	Large Washer (M8 x 20mm x 1mm)	1
65	Lock Washer (M8)	6
66	Warning label	1
67	Wrench	1
68	Allen Wrench (6mm)	1
69	Manual	1

